

NOTE

 PRIMARY DIMENSIONS IN MM.
 ALTERNATE DIMENSIONS IN BRACKETS IN INCHES.

MODEL	PIPE SIZE SPP OR NP	HEIGHT		WIDTH OF BASE		OVERALL WIDTH		DEPTH		WEIGHT	
		mm	Inch	mm	Inch	mm	Inch	mm	Inch	kg	lbs
FBP HL 075	1"	1595	63	559	22	630	25	682	27	186	410
FBP HL 080	1"	1745	69	559	22	630	25	682	27	198	437
FBP HL 085	1-1/2"	2105	83	559	22	630	25	682	27	235	518

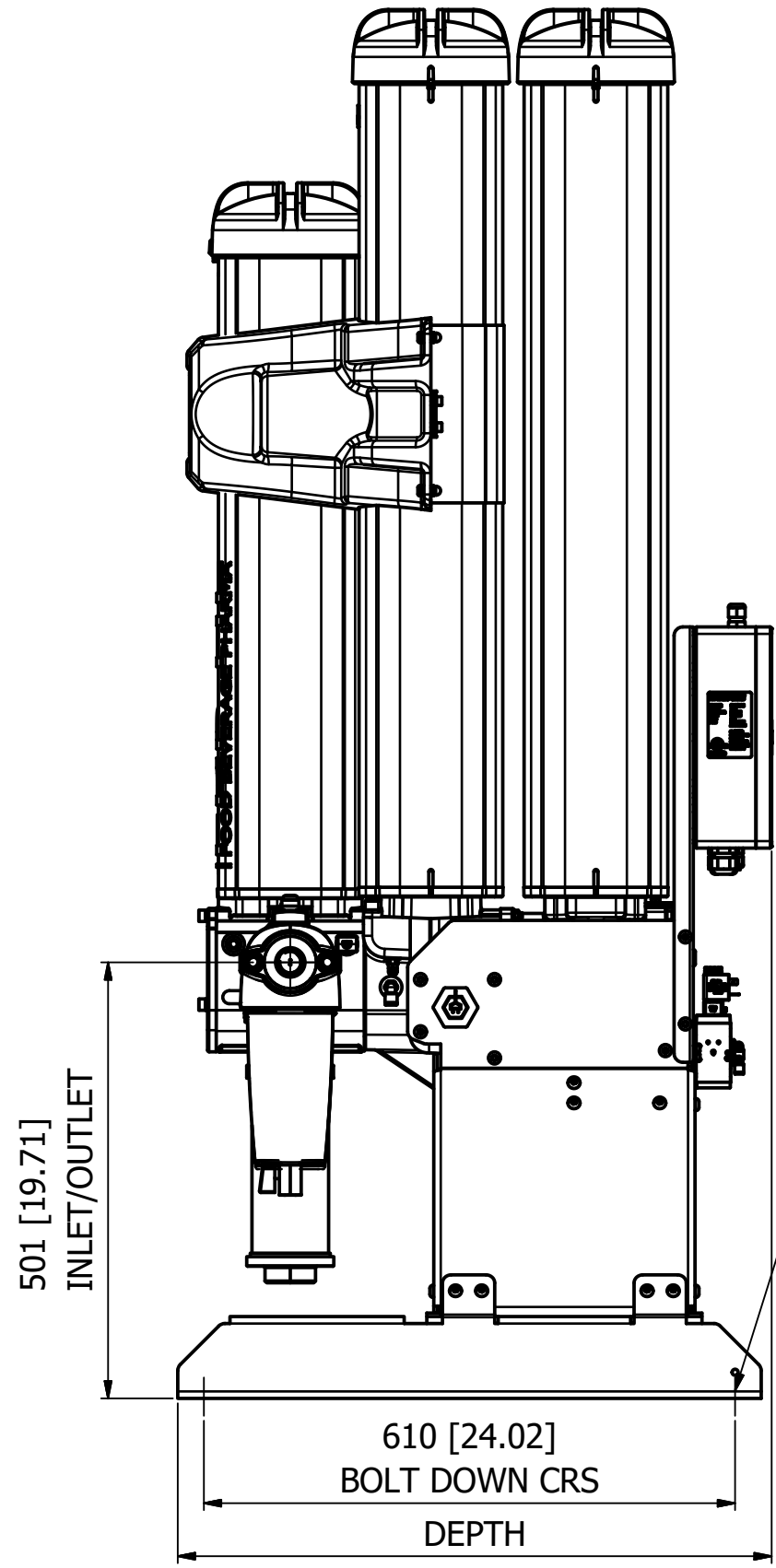
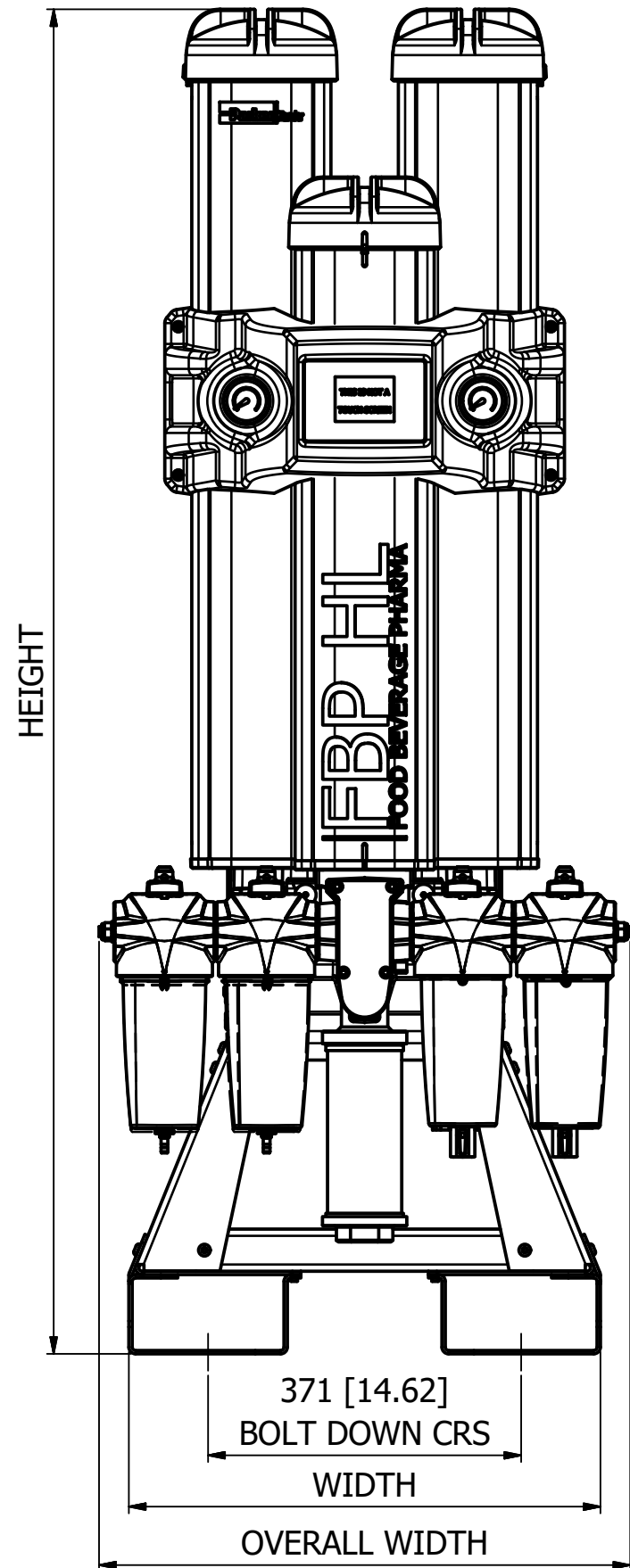

ECO No. 0304036 REV B

PLEASE CONSIDER THE ENVIRONMENT PRIOR TO PRINTING THIS DRAWING

DO NOT SCALE - IF IN DOUBT ASK

BASED ON BS 8888 DIMENSIONS IN MILLIMETRES

GENERAL TOLERANCES UNLESS OTHERWISE STATED

MACHINED DIMENSIONS
 .XX ±0.13 UP TO 300 ±0.3
 .X ±0.25 OVER 300 TO 600 ±0.5

POSITIONAL TOLERANCE
 PLAIN HOLES Ø0.13
 TAPPED HOLES Ø0.26
 CONCENTRICITY TOLERANCE 0.13 TIR

MACHINED SURFACES INDICATED THUS
 SURFACE TEXTURE TO BS 1134
 VALUES IN MICROMETRES

ANGLES ±1/2° (EXCEPT CHAMFERS)

METRIC THREADS TO BS 3643 MED. CLASS
 EXTERNAL 6g INTERNAL 6H
 PIPE THREADS
 PRESSURE TIGHT TO BS 21

SHEET METALWORK & FABRICATIONS
 SHEET METALWORK DIMENSIONS
 UP TO 500 ±0.5
 OVER 500 TO 1000 ±1.0
 OVER 1000 ±1.5

FABRICATED PARTS DIMENSIONS
 UP TO 500 ±2
 OVER 500 TO 1000 ±4
 OVER 1000 ±6

POSITIONAL TOLERANCE FOR PLAIN & TAPPED HOLES
 UP TO 500 Ø1.0
 OVER 500 Ø2.0

Parker | **domnick hunter**

Parker Hannifin Manufacturing Ltd
 domnick hunter Filtration & Separation Division
 Dukesway, Team Valley
 Gateshead, Tyne & Wear
 England, NE11 0PZ
 TEL +44 (0)191 402 9000
 FAX +44 (0)191 482 6296
 www.parker.com/dhfn

THIS DOCUMENT IS COPYRIGHT AND IS THE PROPERTY OF PARKER HANNIFIN LTD. IT MUST NOT BE COPIED IN WHOLE OR PART, USED FOR MANUFACTURE OF, OR OTHERWISE DISCLOSED WITHOUT PRIOR WRITTEN CONSENT OF THE COMPANY

© 2016 **A3**

MATERIAL GEN. ARRT.	SCALE 1:8			DRAWN MG	CHECKED EJ	APPROVED KW	TITLE DIMENSIONAL DRG FBP HL 075-085	DRG No. 101-10516	SHEET 1 / 1
				DATE 21/09/2017	DATE 26/09/2017	DATE 26/09/2017			